

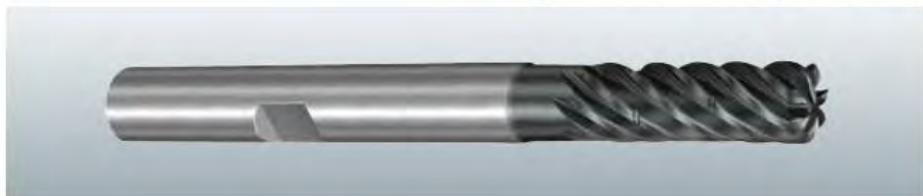

Best of Brands 2024

Fertigungstechnik
Technique de production

Tools. Next Level.

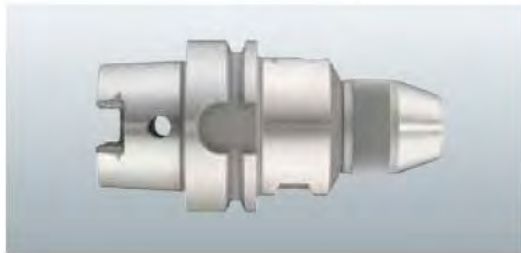
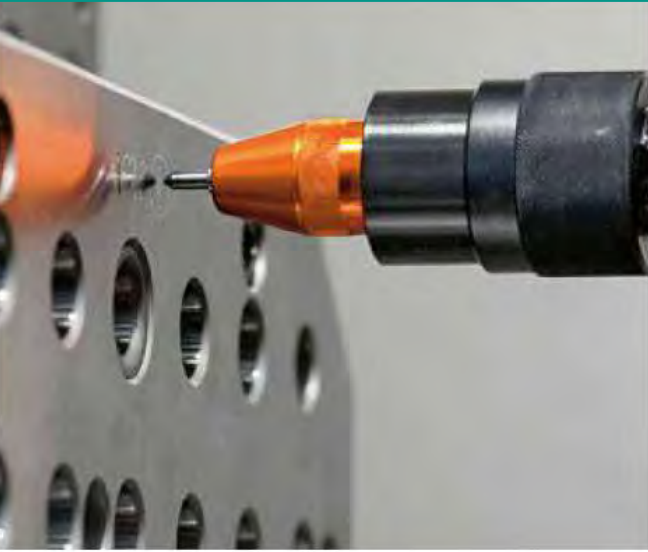

AKTION / ACTION
01.11.2024 –
31.12.2024





FUTURO

226930

FUTURO VHM-Eck-/ Nutfräser (Typ NRF)

FUTURO Fraises à dresser/ rainurer en carbure (Type NRF)

VHM	Ø 6-16	TiAIN	45°	h6	NORM				4-5
P	M	K	N	S	H	O			
O	O								

Rabatt: 35%
Rabais: 35%

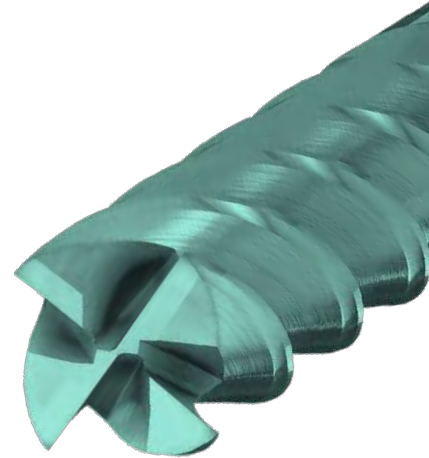

FRÄSEN / FRAISAGE



SANDVIK coromant

224526

COROMANT VHM-Eck-/ Nutfräser CoroMill Dura (2xD)

COROMANT Fraises à dresser/ rainurer en carbure CoroMill Dura (2xD)

VHM	Ø 6-20	AlCrN	35°	h10	h6	DIN 6535				4
P	M	K	N	S	H	O				
●●	●●	●●	●●	●●						

Rabatt: 30%
Rabais: 30%



SANDVIK coromant

224533

COROMANT VHM-Eckfräser CoroMill Dura (3xD)

COROMANT Fraise à dresser en carbure CoroMill Dura (3xD)

VHM	Ø 6-25	AlCrN	37°	h10	h6	DIN 6535			7
P	M	K	N	S	H	O			
●●	●●	●●	●●	●●					

Rabatt: 30%
Rabais: 30%



FUTURO

225737

FUTURO VHM-Eck-/ Nutfräser

FUTURO Fraises à dresser/ rainurer en carbure

VHM	Ø 3-20	AlTiN	35°/38°	h10	h6	DIN 6527L					4
P	M	K	N	S	H	O					
○	●●	●	●	●	●	●					

Rabatt: 35%
Rabais: 35%



GÜHRING

224001

GÜHRING VHM-Eck-/ Nutfräser (RF100 Sharp)

GÜHRING Fraises à dresser/ rainurer en carbure (RF100 Sharp)

VHM	Ø 4-20	AlCrN	38°/40°	e8		NORM					4
P	M	K	N	S	H	O					
●●	●●	●	●●	●●	●	●					

Rabatt: 30%
Rabais: 30%



GÜHRING

224002

GÜHRING VHM-Eck-/ Nutfräser (RF100 Sharp)

GÜHRING Fraises à dresser/ rainurer en carbure (RF100 Sharp)

VHM	Ø 4-20	AlCrN	38°/40°	e8		NORM					4
P	M	K	N	S	H	O					
●●	●●	●	●●	●●	●	●					

Rabatt: 30%
Rabais: 30%



NERIOX

227876

NERIOX VHM-Eck-/ Nutfräser (HPC)

NERIOX Fraises à dresser/ rainurer en carbure (HPC)

VHM	∅ 3-20	TiAIN	35°/38°	h10	h6	NORM					4
P	M	K	N	S	H	O		HPC			
●●	○	●●									

Rabatt:
Rabais: 30%



magafor

222700

MAGAFOR VHM-Eck-/ Nutfräser (Micrograin K15)

MAGAFOR Fraises à dresser/ rainurer en carbure (Micrograin K15)

VHM	∅ 0.05-14	30°		NORM				2			
P	M	K	N	S	H	O					
○	○	○	○	○							

Rabatt:
Rabais: 35%

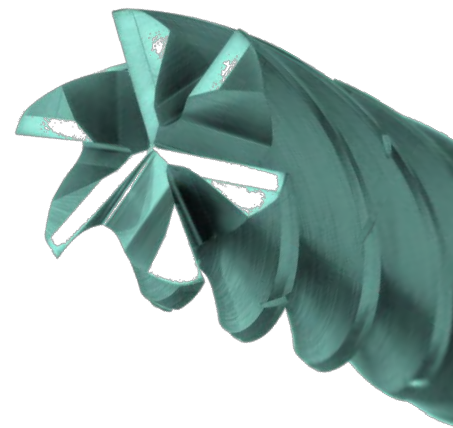

DIXI
polytool

223771

DIXI VHM-Eck-/ Nutfräser (7365)

DIXI Fraises à dresser/ rainurer en carbure (7365)

VHM	∅ 4-20	Coated	41°/48°	d12	h5	NORM						3	
P	M	K	N	S	H	O				HPC			
			●●										

Rabatt:
Rabais: 20%



FRANKEN EMUGE
FRANKEN

221158

FRANKEN VHM-Eckfräser (TOP-CUT)

FRANKEN Fraise à dresser en carbure (TOP-CUT)

VHM	Ø 5-20	TiAIN	35°/38°	f8	h5	DIN 6527						6-8
P	M	K	N	S	H	O						
○	○	○	○	○	○	○						

Rabatt: **25%**
Rabais: **25%**

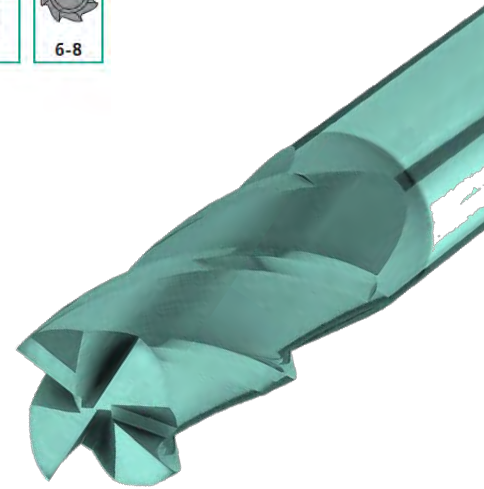

FUTURO

225963

FUTURO VHM-Eckfräser 3xD (zum dynamischen Fräsen)

FUTURO Fraise d'angle en carbure 3xD (pour le fraisage dynamique)

HM	Ø 6-20	Coated	30°/31°	e8	h6						6
P	M	K	N	S	H	O					
●●		●●									

Rabatt: **20%**
Rabais: **20%**



FRANKEN EMUGE
FRANKEN

221700

FRANKEN VHM-Eckfräser (Hard-Cut)

FRANKEN Fraise d'angle en carbure (Hard-Cut)

VHM	Ø 5-16	TiAIN	50°	h5	DIN 6535					HSC
P	M	K	N	S	H	O				
○		○			●●					

Rabatt: **25%**
Rabais: **25%**

FUTURO

240115

FUTURO Eckfräser 90° (für AP..1003)

FUTURO Fraise d'angle 90° (pour AP..1003)

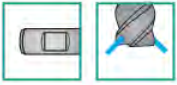

Rabatt: 25%
Rabais: 25%

240116

FUTURO Eckfräser 90° (für AP..1003)

FUTURO Fraise d'angle 90° (pour AP..1003)



Rabatt: 25%
Rabais: 25%

FUTURO

240124

FUTURO Fräs-Wendeschneidplatte (APHT)

FUTURO Plaquette amovible de fraisage (APHT)



Rabatt: 30%
Rabais: 30%

FUTURO

240122

FUTURO Fräs-Wendeschneidplatte (APKT)

FUTURO Plaquette amovible de fraisage (APKT)

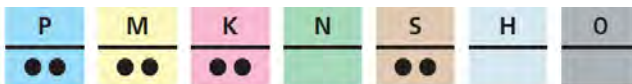

Rabatt: 30%
Rabais: 30%

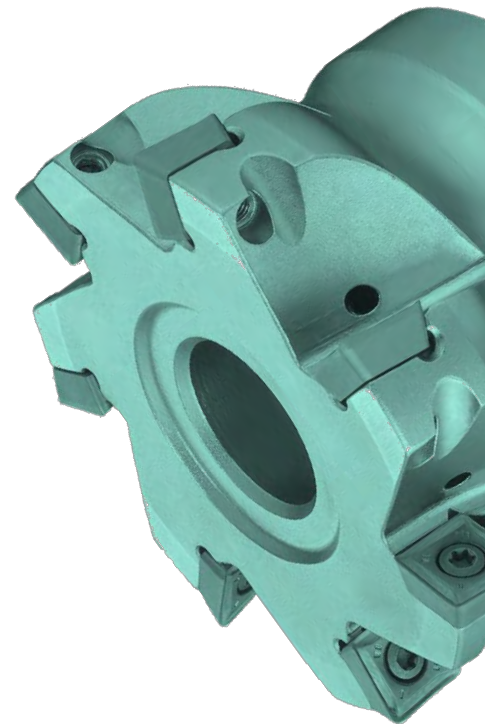

SANDVIK
coromant

232475

COROMANT Plan-, Eckfräser CoroMill MS60

COROMANT Fraise à surfacer

et en bout CoroMill MS60



Rabatt: **40%**
Rabais:

 Brütsch-Rüegger
Tools

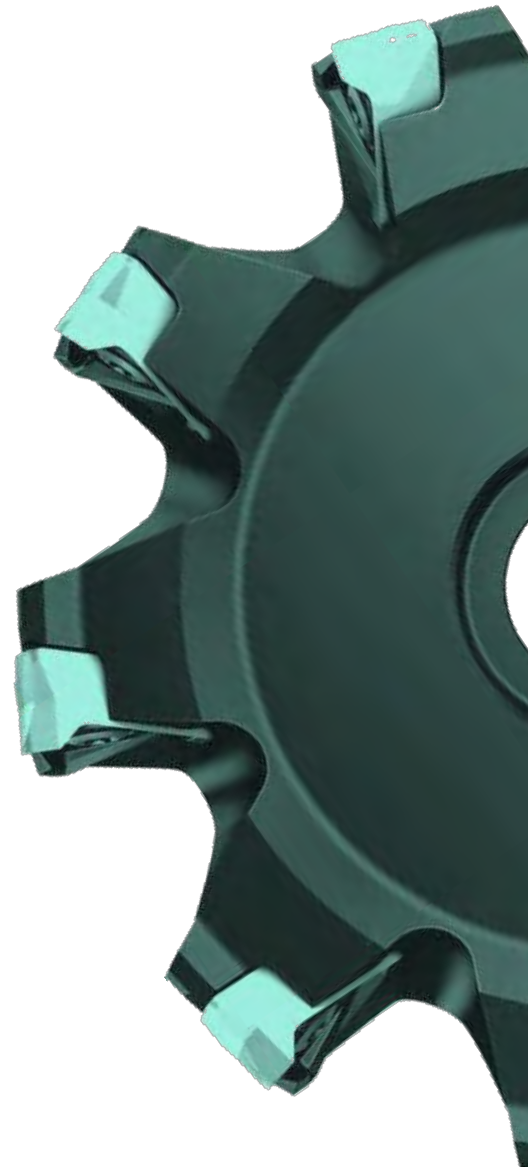

WPL-Fräsen / Fraise à plaquette

SANDVIK
coromant

232476

COROMANT Wendeplatte CoroMill MS60

Mit 6 Indexierungsoptionen

COROMANT Plaquette CoroMill MS60

Avec 6 options d'indexation

P	M	K	N	S	H	O
● ●	● ●	● ●		● ●		○

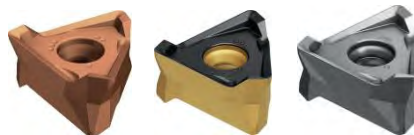

Rabatt: **25%**
Rabais:

230500

ISCAR Zylindrischer Schaft Multi-Master

ISCAR Queue cylindrique Multi-Master



Rabatt: 15%
Rabais: 15%

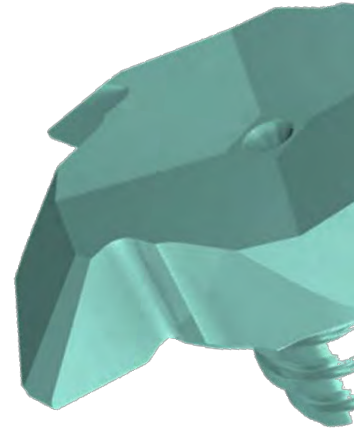

WFK-Fräsen / Tête de fraisage

230650

ISCAR Fräskopf Multi-Master

ISCAR Tête de fraisage Multi-Master

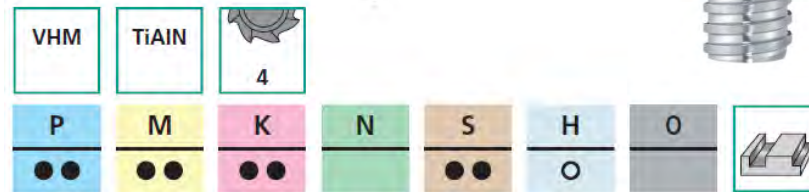

Rabatt: 20%
Rabais: 20%

230600

ISCAR Fräskopf Multi-Master

ISCAR Tête de fraisage Multi-Master

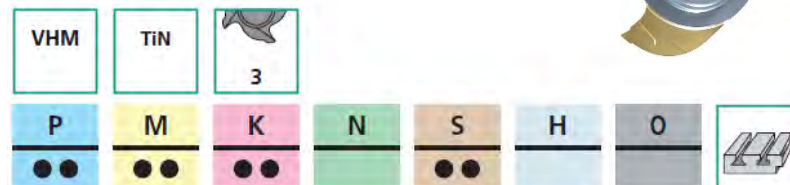

Rabatt: 20%
Rabais: 20%



FUTURO

255520

FUTURO VHM-Spiralbohrer (Ultra-Feinsorte K/P)

FUTURO Foret hélicoïdal en carbure (ultra-fin K/P)

VHM	Ø 3-16	TiAIN	140°		DIN 6537	3xD	
P	M	K	N	S	H	O	
●●	○	●●	○	○	○	○	

Rabatt:
Rabais: 35%

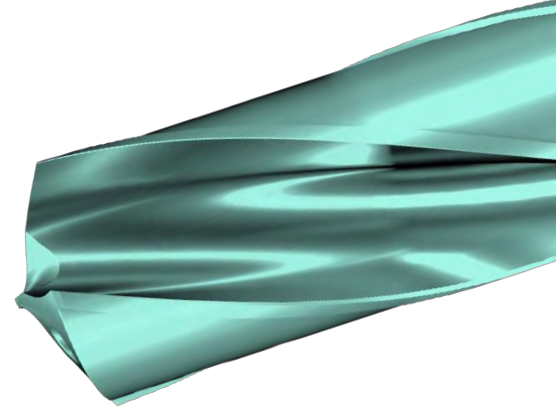

FUTURO

255572

FUTURO VHM-Spiralbohrer (5xD)

FUTURO Foret hélicoïdal en carbure (5xD)

VHM	Ø 3-16	Coated	30°	140°	h6	h6	DIN 6537	5xD	2	
P	M	K	N	S	H	O				
●●	●●	●●	○	●●	○	○				

Rabatt:
Rabais: 35%



WALTER TITEX

252465

WALTER TITEX Spiralbohrer (DIN 1897)

WALTER TITEX Foret hélicoïdal (DIN 1897)

HSS-E	Ø 1-20	AlCrN	130°		DIN 1897		
P	M	K	N	S	H	O	
●●	●●	●●	●●	●●	○	○	

Rabatt:
Rabais: 40%



252225

WALTER TITEX Spiralbohrer (DIN 338)

WALTER TITEX Foret hélicoïdal (DIN 338)

HSS-E	Ø 1-16	AlCrN	130°		DIN 338			
P	M	K	N	S	H	O		
●●	●●	●●	●●	○		○		

Rabatt: 40%
Rabais:

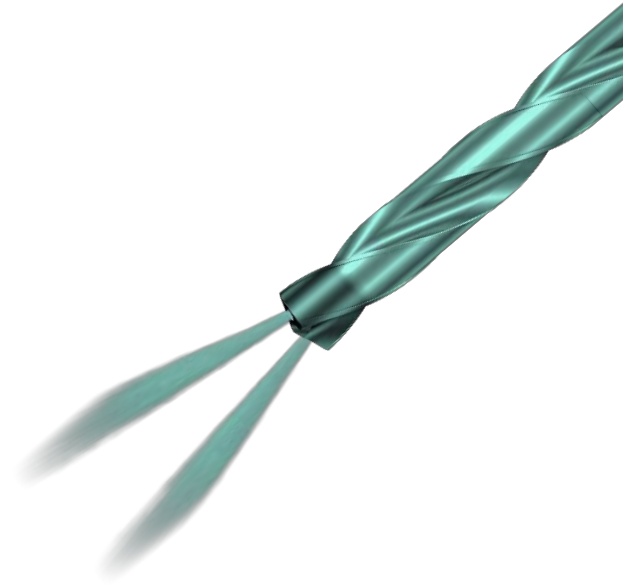

255041

WALTER TITEX VHM-Spiralbohrer DC150 Perform (5xD)

WALTER TITEX Foret hélicoïdal en carbure DC150 Perform (5xD)

VHM	Ø 3-20	TiAlN	30°	140°	m7	h6	DIN 6537	5xD	2	
P	M	K	N	S	H	O				
●●	○	●●	○	○	○					

Rabatt: 30%
Rabais:



255030

WALTER TITEX VHM-Spiralbohrer DC150 (3xD) Perform

WALTER TITEX Foret hélicoïdal en carbure DC150 (3xD) Perform

VHM	Ø 3-20	Coated	30°	140°	m7	h6	DIN 6537K	3xD	2	
P	M	K	N	S	H	O				
●●	○	●●	○	○	○					

Rabatt: 30%
Rabais:

FUTURO

254491

FUTURO Sortiment Spiralbohrer

FUTURO Assortiment de forets hélicoïdaux

HSS-E Co5	135°	h8	≥ 4	DIN 338			
P	M	K	N	S	H	O	
●●	●●	○	●●	○			

Rabatt: 30%
Rabais: 30%



NERIOX

254416

NERIOX Sortiment Spiralbohrer

NERIOX Assortiment de forets hélicoïdaux

HSS	TIN	118°		DIN 338			
P	M	K	N	S	H	O	
●●		●●	○				

Rabatt: 25%
Rabais: 25%



FUTURO

257651

FUTURO Sortiment Mehrstufenbohrer

FUTURO Assortiment de forets à chamber étagés

HSS-E Co5	Coated						
P	M	K	N	S	H	O	
●●	●●	○	●●	○			○

Rabatt: 30%
Rabais: 30%



SANDVIK
coromant

256350

COROMANT Wendepplattenbohrer CoroDrill 880 (3xD)

COROMANT Foret à plaquettes amovibles CoroDrill 880 (3xD)



Rabatt: **20%**
Rabais:

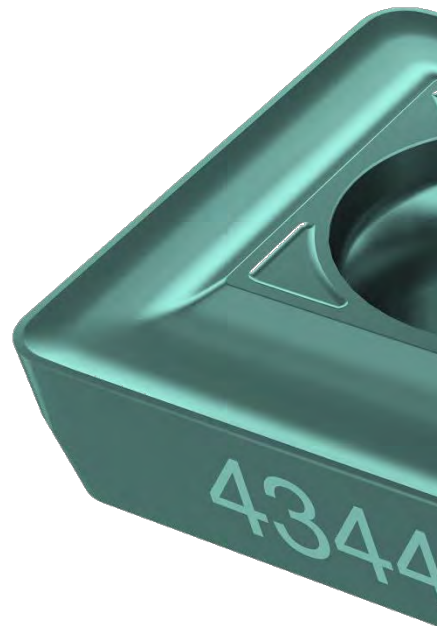

SANDVIK
coromant

256360

COROMANT Wendepplatte zu CoroDrill 880

COROMANT Plaquette indexable pour CoroDrill 880

P	M	K	N	S	H	O
● ●	● ●	○	● ●	● ●	● ●	



Rabatt: **30%**
Rabais:

GÜHRING

256260

GÜHRING VHM-Tieflochbohrer RT100 (15xD)

GÜHRING Foret pour trous profonds en carbure RT100 (15xD)

VHM	Ø 3-14	TIAlN	135°	h7	h6	NORM	15xD	
P	M	K	N	S	H	O		
● ●	● ●	● ●	○	○				



Rabatt: **30%**
Rabais:

256455

ISCAR Wendepplattenbohrer SUMOCHAM (5xD)

ISCAR Foret à plaquette SUMOCHAM (5xD)



Rabatt: 20%
Rabais: 20%

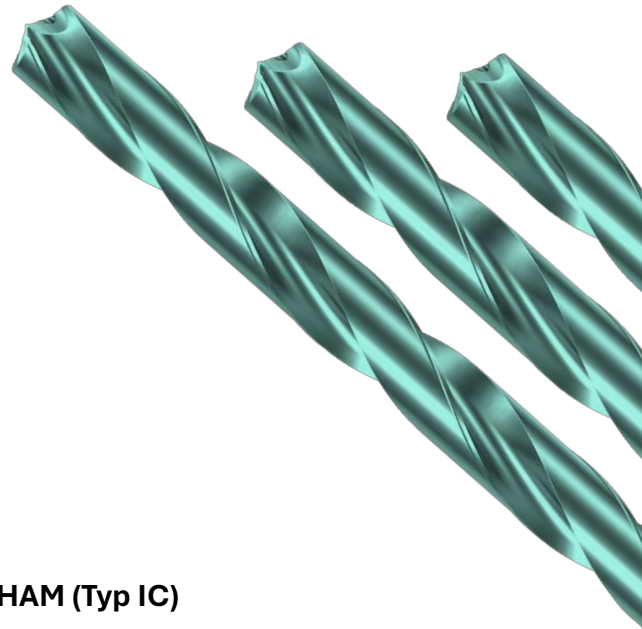

256490

ISCAR Bohr-Wechselkopf SUMOCHAM (Typ IC)

ISCAR Tête de perçage interchangeable SUMOCHAM (Type IC)

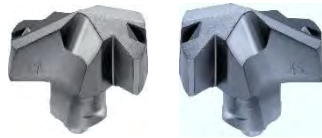
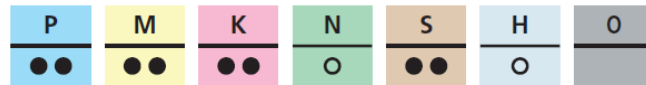

Rabatt: 30%
Rabais: 30%

GÜHRING

256265

GÜHRING VHM-Tieflochbohrer RT100 (20xD)

GÜHRING Foret pour trous profonds en carbure RT100 (20xD)

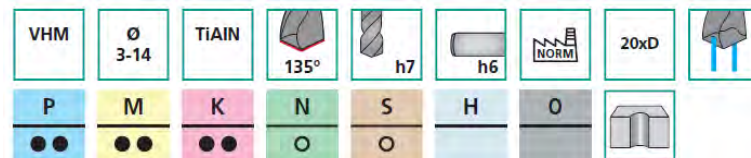

Rabatt: 30%
Rabais: 30%



FUTURO

264100

FUTURO Hochleistungs-Gewindebohrer, metrisch ISO-Gewinde

FUTURO Taraud à haute performance, Filetage métrique ISO

HSS-E PM	THL	M	RH	6HX	B 3.5-5.5	2-4	
P	M	K	N	S	H	O	

Rabatt: 30%
Rabais:

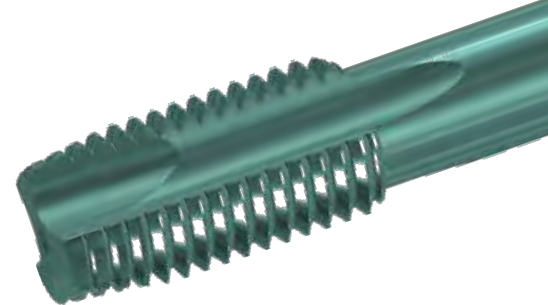

FUTURO

264105

FUTURO Hochleistungs-Gewindebohrer, metrisch ISO-Gewinde

FUTURO Taraud à haute performance, Filetage métrique ISO

HSS-E PM	THL	M	RH	6HX	C 2-3	3-4	
P	M	K	N	S	H	O	

Rabatt: 30%
Rabais:

Gewinden / Taraudage



261530

DC Gewindebohrer QTAP, Metrisches ISO-Gewinde

DC Taraud QTAP, Filetage métrique ISO

HSS-E PM	VS	M	RH	6H	B 3.5-5.5	3-4	
P	M	K	N	S	H	O	QTAP

Rabatt: 30%
Rabais:



261535

DC Gewindebohrer QTAP, Metrisches ISO-Gewinde

DC Taraud QTAP, Filetage métrique ISO

HSS-E PM	VS	M	RH	6H	C 2-3	3-4	
P	M	K	N	S	H	O	QTAP
●●	●●	●●	●●	○		○	<2.5 x D

Rabatt: 30%
Rabais: 30%

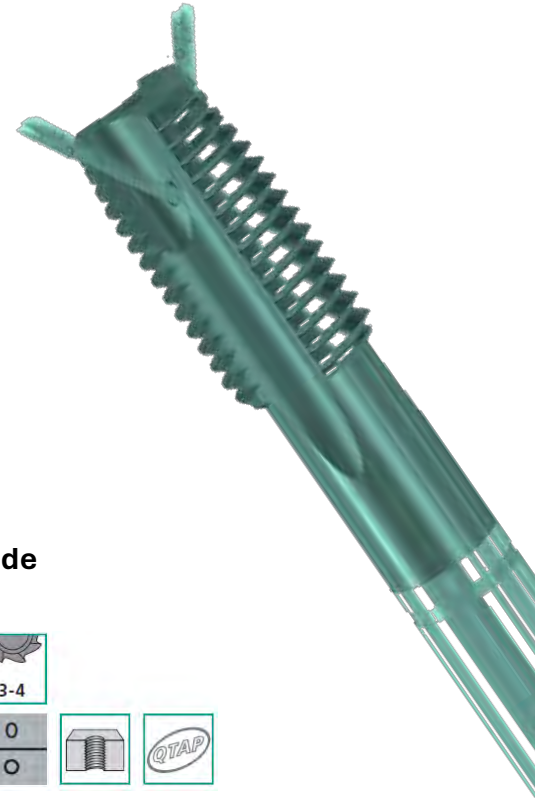

Gewinden / Taraudage



263310

DC Gewindebohrer QTAP, Rohrgewinde

DC Taraud QTAP, Filetage Gaz

HSS-E PM	VS	G	RH	B 3.5-5.5	3-4		
P	M	K	N	S	H	O	QTAP
●●	●●	●●	●●	○		○	<2.5 x D

Rabatt: 30%
Rabais: 30%



263312

DC Gewindebohrer QTAP, Rohrgewinde

DC Taraud QTAP, Filetage Gaz

HSS-E PM	VS	G	RH	C 2-3	3-4		
P	M	K	N	S	H	O	QTAP
●●	●●	●●	●●	○		○	<2.5 x D

Rabatt: 30%
Rabais: 30%



261140

DC Gewindebohrer, Metrisches ISO-Gewinde

DC Taraud, Filetage métrique ISO

HSS-E PM	VS	M	RH	ISO 2 (6H)	B 3.5-5.5	3-4		
P	M	K	N	S	H	O		Z

Rabatt: 25%
Rabais: 25%



261210

DC Gewindebohrer, Metrisches ISO-Gewinde

DC Taraud, Filetage métrique ISO

HSS-E PM	VS	M	RH	6HX	C 2-3	3-4		
P	M	K	N	S	H	O		Z

Rabatt: 25%
Rabais: 25%



261080

DC Gewindebohrer, Metrisches ISO-Gewinde

DC Taraud, Filetage métrique ISO

HSS-E PM	M	RH	ISO 2 (6H)	B 3.5-5.5	2-3			
P	M	K	N	S	H	O		W

Rabatt: 25%
Rabais: 25%



261100

DC Gewindebohrer, Metrisches ISO-Gewinde

DC Taraud, Filetage métrique ISO

HSS-E	M	RH	ISO 2 (6H)	C 2-3	2-3	
P	M	K	N	S	H	O

<2.5 x D

Rabatt: 25%
Rabais: 25%

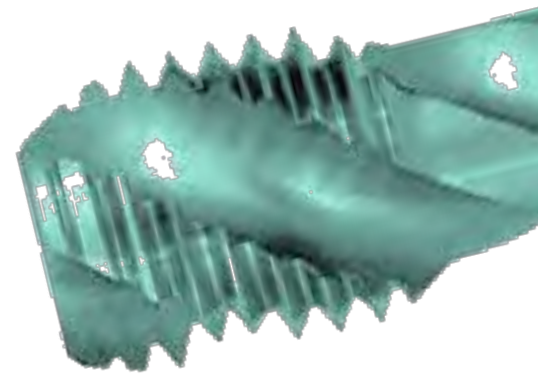

Gewinden / Taraudage



264770

VARDEX VHM-Gewindefräser, Metrisches ISO-Gewinde

VARDEX Fraise à fileter en carbure, Filetage métrique ISO

VHM	TiCN	M	RH	6H	3-4	
P	M	K	N	S	H	O
O	O	O	O	O	O	O

<2 x D

Rabatt: 20%
Rabais: 20%



264760

VARDEX VHM-Gewindefräser, Metrisches ISO-Gewinde

VARDEX Fraise à fileter en carbure, Filetage métrique ISO

VHM	TiCN	M	RH	6H	3-5	
P	M	K	N	S	H	O
O	O	O	O	O	O	O

<2 x D

Rabatt: 20%
Rabais: 20%

NERIOX

264496

NERIOX Sortiment Gewindebohrer

NERIOX Assortiment de tarauds

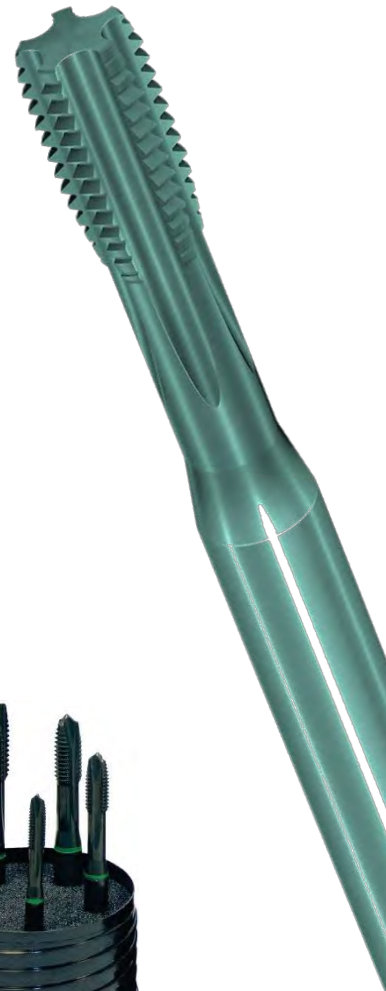
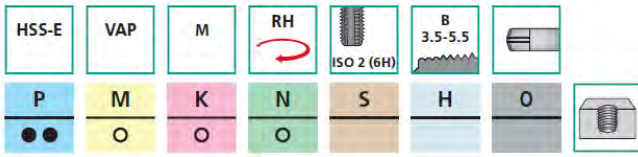

Rabatt: 25%
Rabais: 25%

NERIOX

264491

NERIOX Sortiment Gewindebohrer

NERIOX Assortiment de tarauds

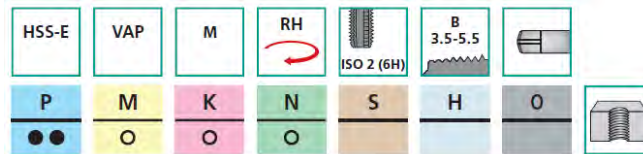

Rabatt: 25%
Rabais: 25%



272220

EDALTOUR Gewindeschneidvorrichtung

EDALTOUR Dispositif de taraudage



1269.- CHF

statt / au lieu de : CHF ~~1410.-~~

Gewinden / Taraudage



BECK
MAPAL GROUP

276270

BECK VHM-Kegelsenker 90° (EUC-Speed)

BECK Fraise conique carbure 90° (EUC-Speed)

VHM	Coated			90°	3		
P	M	K	N	S	H	O	
●●	●●	●●	●●	●●	●●	●●	

Rabatt: 30%
Rabais: 30%

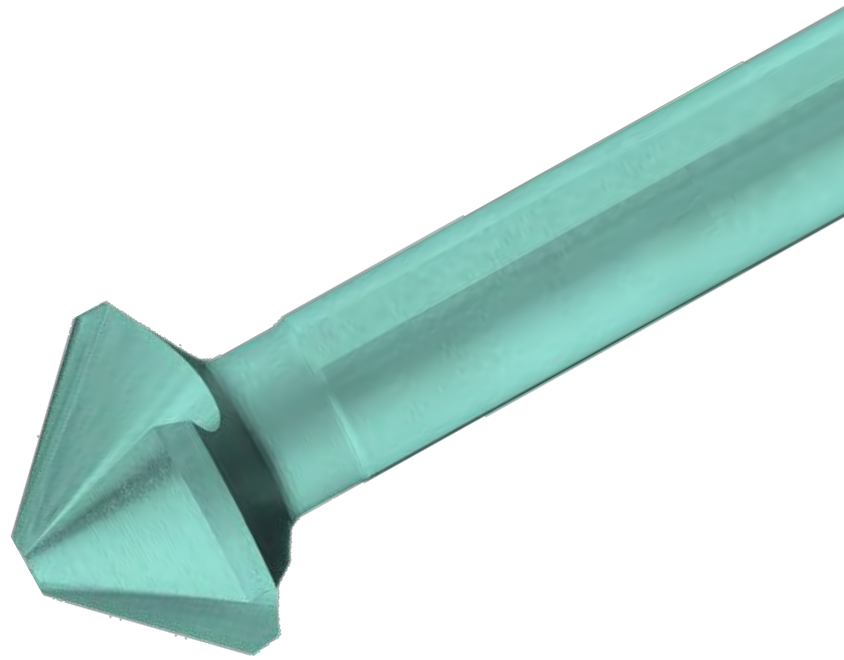

BECK
MAPAL GROUP

276520

BECK Kegelsenker Sortiment 90° (EUC-Speed)

BECK Assortiment de fraises coniques 90° (EUC-Speed)

HSS	Coated			DIN 335C	90°	3	
P	M	K	N	S	H	O	
●●	○	●●	○	○		●●	

Rabatt: 30%
Rabais: 30%



Senken / Chanfreinage



magafor

251120

MAGAFOR NC-Anbohrer 60° (DUO-mag)

MAGAFOR Foret à pointer NC 60° (DUO-mag)

HSS-E	Ø 3-20	Red ' X	60°	h7					
P	M	K	N	S	H	O			
●●	●●	●●	○	●●	○	○			

Rabatt: 40%
Rabais:

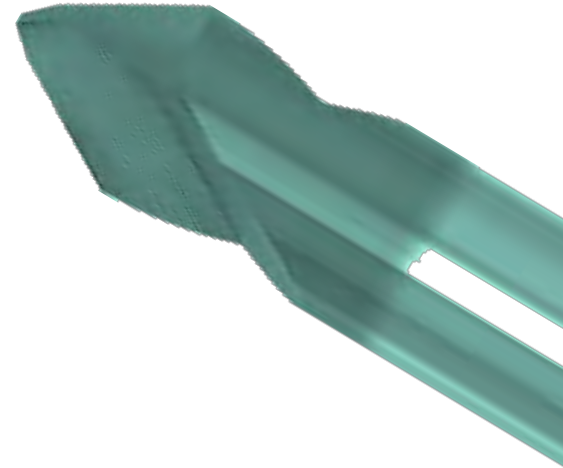

NC-Anbohrer / Mèches à pointer



magafor

250190

MAGAFOR NC-Anbohrer 90°

MAGAFOR Foret à pointer NC 90°

HSS-E	Ø 3-20	Red ' X	90°	h6					
P	M	K	N	S	H	O			
●●	●●	●●	○	●●	○	○			

Rabatt: 35%
Rabais:



FUTURO

250140

FUTURO VHM-NC-Anbohrer 90°

FUTURO Foret à pointer en carbure 90°

VHM	Ø 3-12	TIAIN	90°	h5	h5				
P	M	K	N	S	H	O			
●●	●●	●●	●●	○		○			



Rabatt: 30%
Rabais:

 **magafor**

251250

MAGAFOR Zentrierbohrer mit Radius

MAGAFOR Foret à centrer avec rayon

HSS-E	Ø 1-4		DIN 333						
P	M	K	N	S	H	O			
○	○	○	○	○		○			

Rabatt: 25%
Rabais: 25%



Zentrierbohrer / Mèches à centrer

FUTURO

251137

FUTURO Sortiment Zentrierbohrer 60°

FUTURO Assortiment forets à centrer 60°

HSS	Ø 0.5-4	TiAIN	 h7	DIN 333			
P	M	K	N	S	H	O	
●●	●●		○	○		○	○

Rabatt: 30%
Rabais: 30%

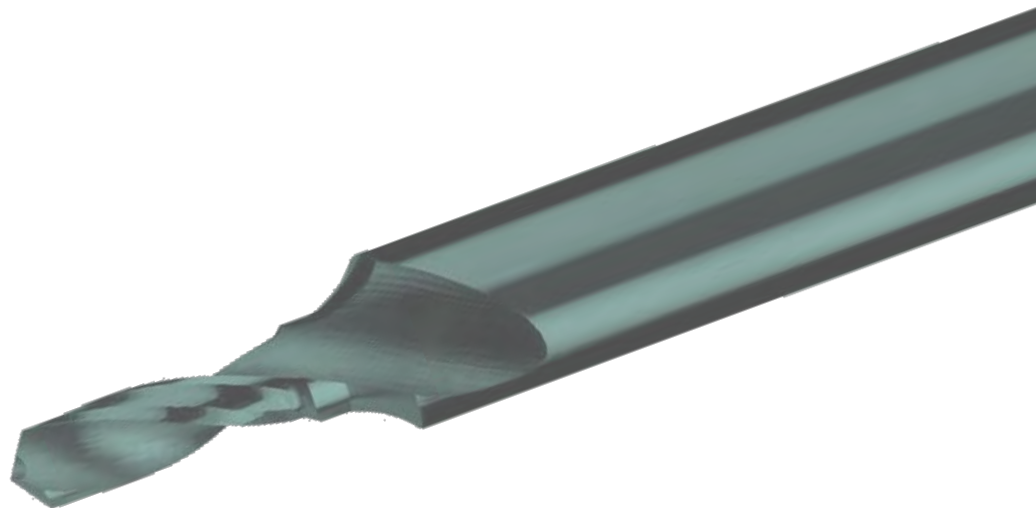



FUTURO

224109

FUTURO VHM-Entgrater 90°

FUTURO Outil à ébavurer carbure 90°

VHM	∅ 3-12	TiAIN						
P	M	K	N	S	H	O		
	●●		○	○				

Rabatt: **25%**
Rabais: **25%**

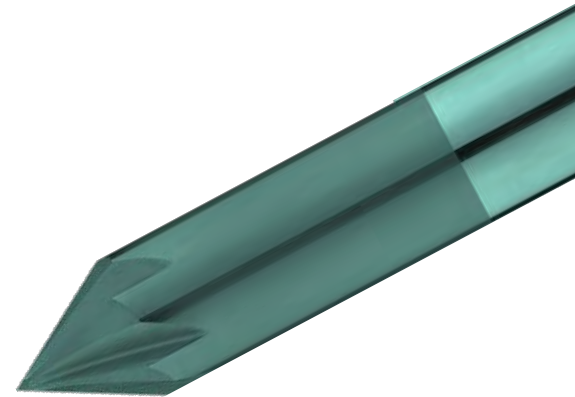

NERIOX

224191

NERIOX VHM-Entgrater 90°

NERIOX Fraise à chanfreiner carbure 90°

VHM	∅ 4-12	TiAIN						
P	M	K	N	S	H	O		
●●	○	○	○					

Rabatt: **35%**
Rabais: **35%**



DIXI polytool

224101

DIXI VHM-Fasfräser 90°

DIXI Fraise à chanfreiner carbure 90°

VHM	∅ 0.5-12	TiAIN						
P	M	K	N	S	H	O		
●●	●●	○		○				

Rabatt: **20%**
Rabais: **20%**

Fasen / Ébavurer



218560

DIXI VHM-Kreissägeblatt

Form A, Winkelzahn, grobgezahnt, ISO 2296

**DIXI Scie circulaire en carbure Forme A,
dents angulaires, denture grossière, ISO 2296**

P	M	K	N	S	H	O
●●	○	●●	○	●●		○



**Rabatt:
Rabais: 15%**



218540

DIXI VHM-Kreissägeblatt

Form A, Winkelzahn, feingezahnt,

Cutinox-Beschichtung, poliert

ähnlich DIN 1837A.

**DIXI Scie circulaire en carbure,
Type A, dents angulaires, denture fine
avec revêtement Cutinox, polie,
similaire à DIN 1837A.**

P	M	K	N	S	H	O
○	●●		○	●●		



**Rabatt:
Rabais: 15%**

Trennen / Tronçonnage

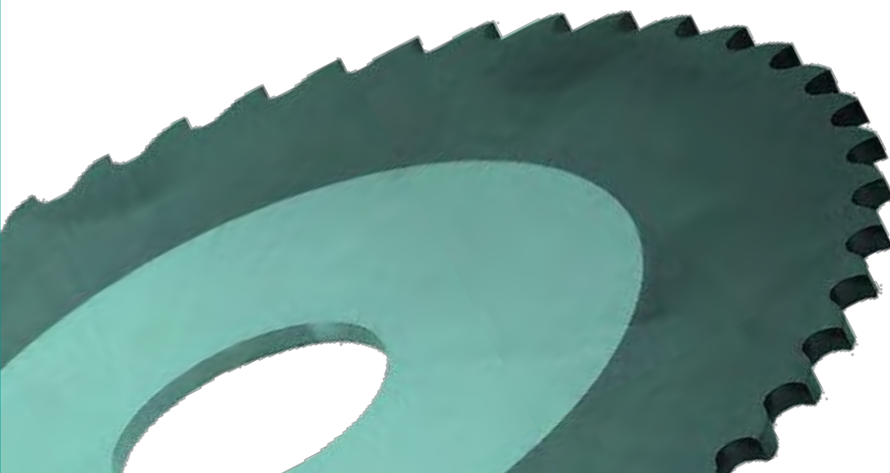

SANDVIK
coromant

300000

COROMANT Werkzeughalter PCLNR/L (T-MAX P)

COROMANT Porte-outil PCLNR/L (T-MAX P)



Rabatt:
Rabais: **20%**

SANDVIK
coromant

302000

COROMANT Wendeplatte CNMG (T-MAX P)

COROMANT Plaquette amovible CNMG (T-MAX P)



P	M	K	N	S	H	O
••	••	••		••		

Rabatt:
Rabais: **35%**

SANDVIK
coromant

300420

COROMANT Werkzeughalter SDJCR/L (CoroTurn 107)

COROMANT Porte-outil SDJCR/L (CoroTurn 107)



Rabatt:
Rabais: **20%**

SANDVIK
coromant

302480

COROMANT Wendeplatte DCMT (CoroTurn 107)

COROMANT Plaquette amovible DCMT (CoroTurn 107)



P	M	K	N	S	H	O
••	••	••		••		

Rabatt:
Rabais: **35%**

Drehen / Tournage

294225

APPLITEC Werkzeughalter SDJCR-11

APPLITEC Porte-outil SDJCR-11



Rabatt: **15%**
Rabais:

294270

APPLITEC Wendeplatte DCGT-11, FN-X17°

APPLITEC Plaquette DCGT-11, FN-X17°

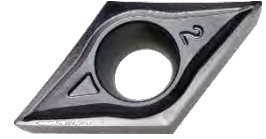

Rabatt: **20%**
Rabais:

294075

APPLITEC Werkzeughalter SCLCR-09

APPLITEC Porte-outil SCLCR-09



Rabatt: **15%**
Rabais:

294105

APPLITEC Wendeplatte DCGT-11, FN-X17°

APPLITEC Plaquette DCGT-11, FN-X17°



Rabatt: **20%**
Rabais:

Drehen / Tournage

SANDVIK
coromant

305101

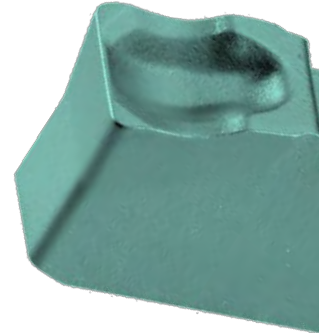
COROMANT Schaftwerkzeug CoroCut® QD*Rechts, mit Präzisionskühlung,
zum Abstechen und Einstechen***COROMANT** Outil à manche CoroCut® QD
*À droite, avec refroidissement de précision,
pour le tronçonnage et les gorges***Rabatt:**
Rabais: **20%****SANDVIK**
coromant

305102

COROMANT Schaftwerkzeug CoroCut® QD*Links, mit Präzisionskühlung,
zum Abstechen und Einstechen***COROMANT** Outil à manche CoroCut® QD
*À gauche, avec refroidissement de précision,
pour le tronçonnage et les gorges***Rabatt:**
Rabais: **20%****SANDVIK**
coromant

305103

COROMANT Schaftwerkzeug CoroCut® QD*Rechts, zum Abstechen und Einstechen***COROMANT** Outil à manche CoroCut® QD
*À droite, pour le tronçonnage et les gorges***Rabatt:**
Rabais: **20%**

**SANDVIK
coromant**

305104

COROMANT Schaftwerkzeug CoroCut® QD
Links, zum Abstechen und Einstechen
COROMANT Outil à manche CoroCut® QD
À gauche, pour le tronçonnage et les gorges

Rabatt: 20%
Rabais:
**SANDVIK
coromant**

305041

COROMANT Wendeplatte (CoroCut® QD)
Wiper, neutral, zum Abstechen
COROMANT Plaquette amovible (CoroCut® QD)
Wiper, neutre, pour le tronçonnage

P	M	K	N	S	H	O
●●	●●	●●	●●	●●	●●	

Rabatt: 35%
Rabais:

**SANDVIK
coromant**

305042

COROMANT Wendeplatte (CoroCut® QD)
neutral, zum Abstechen
COROMANT Plaquette amovible (CoroCut® QD)
neutre, pour le tronçonnage

P	M	K	N	S	H	O
●●	●●	●●	●●	●●	●●	

Rabatt: 35%
Rabais:

SANDVIK
coromant

305044

COROMANT Wendeplatte (CoroCut® QD)

links, zum Abstechen

COROMANT Plaquette amovible (CoroCut® QD)

à gauche, pour le tronçonnage



P	M	K	N	S	H	O
●●	●●	●●	●●	●●	●●	

Rabatt: **35%**
Rabais:

SANDVIK
coromant

305046

COROMANT Wendeplatte (CoroCut® QD)

Rund, zum Profildrehen

COROMANT Plaquette amovible (CoroCut® QD)

Ronde, pour le profilage



P	M	K	N	S	H	O
●●	●●	●●	●●	●●	●●	

Rabatt: **35%**
Rabais:

Drehen / Tournage



304000

VARDEX Werkzeughalter, rechts

Aussengewinde, Steigungswinkel 1.5°

VARDEX Porte-plaquettes, à droite

Filetage extérieur, angle d'inclinaison 1.5°



Rabatt:
Rabais: **15%**

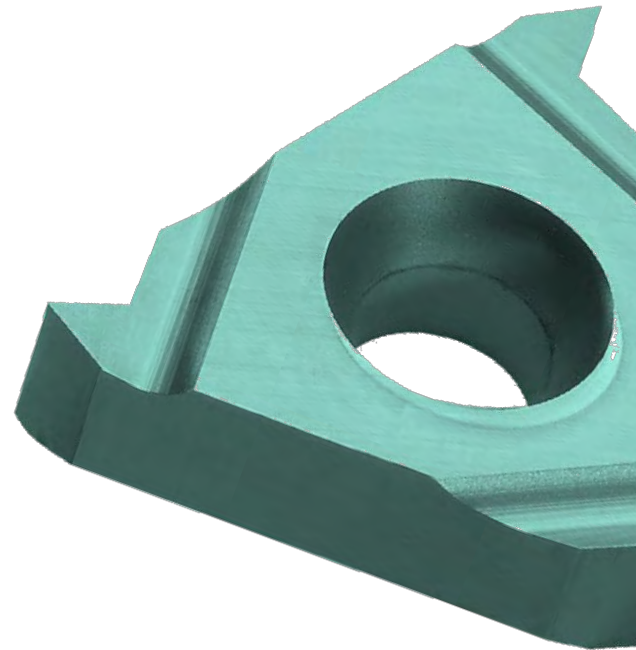

304220

VARDEX HM-Bohrstange, rechts

Innengewinde, mit Innenkühlung, Steigungswinkel 1.5°

VARDEX Barre d'alésage carbure, à droite

Filetage intérieur, à trous d'huile, angle d'inclinaison 1.5°



Rabatt:
Rabais: **15%**

304040

VARDEX Wendeplatte ISO-ER, rechts

Aussengewinde, Vollprofil 60°, metrisch

VARDEX Plaquette amovible ISO-ER, à droite

Filetage extérieur, profil complet 60°, métrique

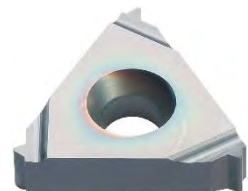

P	M	K	N	S	H	O
O	O	O	O	O		

Rabatt:
Rabais: **30%**

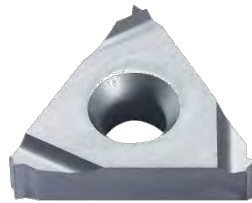

304240

VARDEX Wendeplatte ISO-IR, rechts

Innengewinde, Vollprofil 60°, metrisch

VARDEX Plaquette amovible ISO-IR, à droite

Filetage intérieur, profil complet 60°, métrique

P	M	K	N	S	H	O
○	○	○	○	○		

Rabatt:
Rabais: **30%**

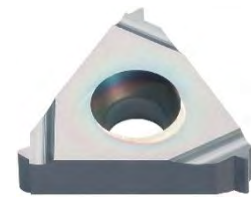

304100

VARDEX Wendeplatte ER-W, rechts (Withworth)

Aussengewinde, Vollprofil 55° W, (BSW, BSP(G), BSF)

VARDEX Plaquette amovible ER-W, à droite (Withworth)

Filetage extérieur, profil complet 55° W, (BSW, BSP(G), BSF)

P	M	K	N	S	H	O
○	○	○	○	○		

Rabatt:
Rabais: **25%**

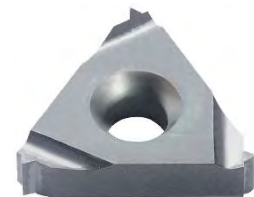

304280

VARDEX Wendeplatte IR-W, rechts Withworth

Innengewinde, Vollprofil 55° W, (BSW, BSP(G), BSF)

VARDEX Plaquette amovible IR-W, à droite (Withworth)

Filetage intérieur, profil complet 55° W, (BSW, BSP(G), BSF)

P	M	K	N	S	H	O
○	○	○	○	○		

Rabatt:
Rabais: **25%**



304260

VARDEX Wendeplatte IR-60, rechts
Innengewinde, Teilprofil 60°

VARDEX Plaquette amovible IR-60, à droite
Filetage intérieur, profil partiel 60°

P	M	K	N	S	H	O
○	○	○	○	○		

Rabatt:
Rabais: **25%**

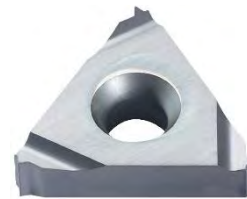

304240

VARDEX Wendeplatte ISO-IR, rechts
Innengewinde, Vollprofil 60°, metrisch

VARDEX Plaquette amovible ISO-IR, à droite
Filetage intérieur, profil complet 60°, métrique

P	M	K	N	S	H	O
○	○	○	○	○		

Rabatt:
Rabais: **30%**

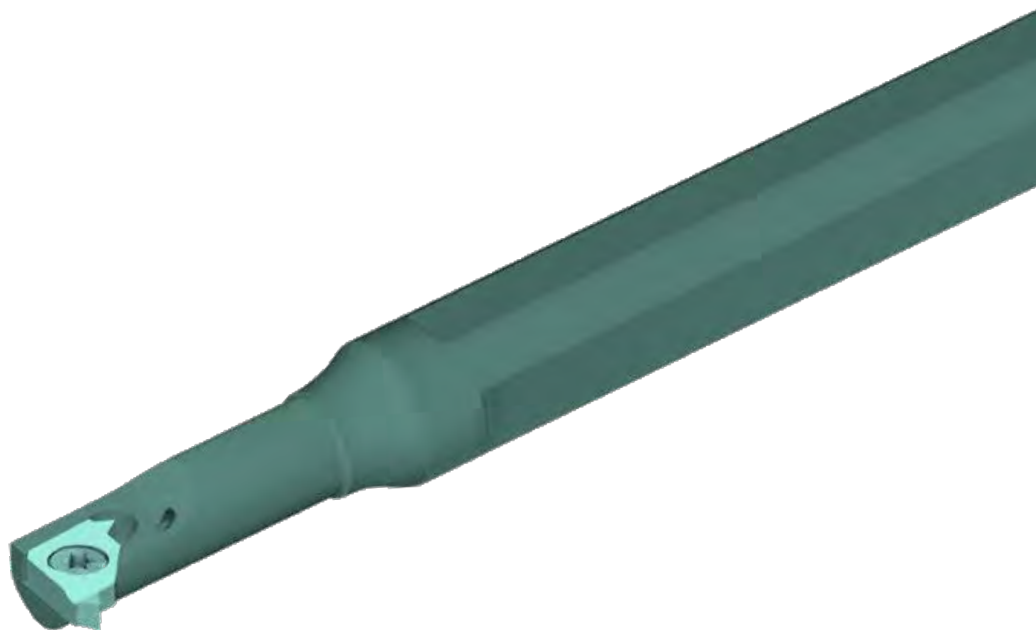

Drehen / Tournage



BECK
MAPAL GROUP

284351

BECK VHM-Hochleistungsreibahle (HNC-PLUS)

BECK Alésoir à haute performance en carbure (HNC-PLUS)

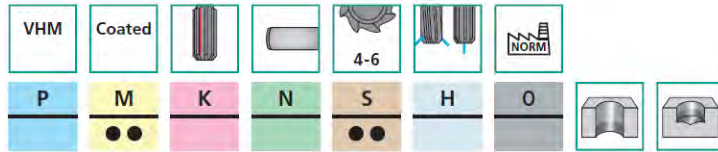

Rabatt: 20%
Rabais: 20%

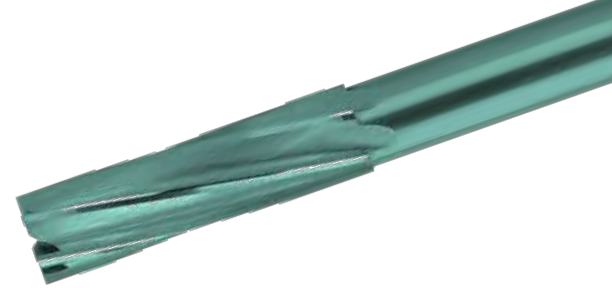

Reiben / Alésage



BECK
MAPAL GROUP

284352

BECK VHM-Hochleistungsreibahle (HNC-PLUS)

BECK Alésoir à haute performance en carbure (HNC-PLUS)



Rabatt: 20%
Rabais: 20%



BECK
MAPAL GROUP

284350

BECK VHM-Hochleistungsreibahle (HNC-PLUS)

BECK Alésoir à haute performance en carbure (HNC-PLUS)

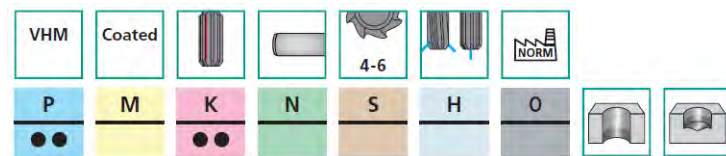

Rabatt: 20%
Rabais: 20%



BECK
MAPAL GROUP

282305

BECK HSS-Hochleistungsreibahle (HNC ecoSpeed)

BECK Alésoir à haute performance HSS (HNC ecoSpeed)

HSS	Coated					
P	M	K	N	S	H	O
●●		●●				

Rabatt: 15%
Rabais: 15%

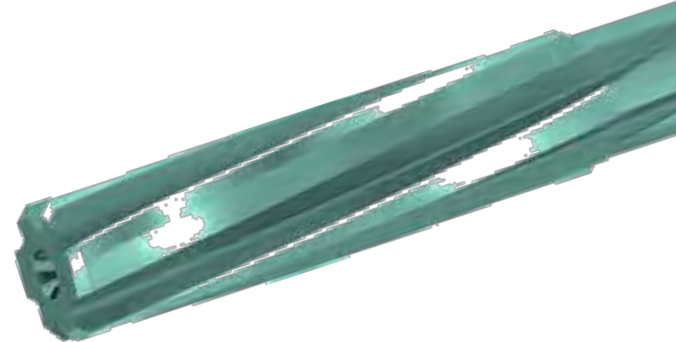

BECK
MAPAL GROUP

282300

BECK HSS-Hochleistungsreibahle (HNC ecoSpeed)

BECK Alésoir à haute performance HSS (HNC ecoSpeed)

HSS	Coated					
P	M	K	N	S	H	O
●●		●●				

Rabatt: 15%
Rabais: 15%



BECK
MAPAL GROUP

282080

BECK Maschinenreibahle (TiN-Beschichtung)

BECK Alésoir machine (revêtement TiN)

HSS-E	TiN					
P	M	K	N	S	H	O
●●	○	○				

Rabatt: 30%
Rabais: 30%

Reiben / Alésage



DIXI
polytool

284085

DIXI VHM-Maschinenreibahle

DIXI Alésoir machine en carbure monobloc

VHM								
P	M	K	N	S	H	O		
●●	●●	●●	●●	○		○		

Rabatt: 20%
Rabais: 20%

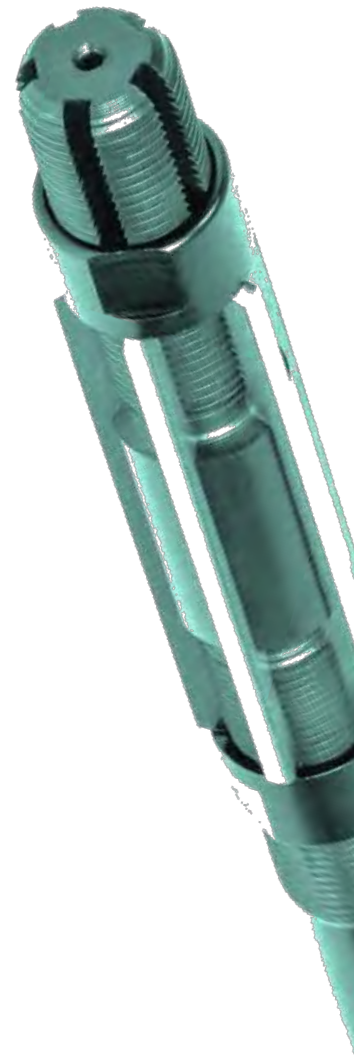

DIXI
polytool

284081

DIXI VHM-Maschinenreibahle

DIXI Alésoir machine en carbure monobloc

VHM							
P	M	K	N	S	H	O	
●●	●●	●●	●●	○		○	

Rabatt: 20%
Rabais: 20%

Reiben / Alésage



BECK
MAPAL GROUP

282461

BECK Handreibahle verstellbar (Schnell verstellbar)

BECK Alésoir à main réglable (réglable rapidement)

HSS-E	TiN					
P	M	K	N	S	H	O
●●	○	○				○

Rabatt: 25%
Rabais: 25%

REGO-FIX▲

330500

REGO-FIX Spannzangenfutter DIN 69871, Form AD

gewuchtet für 22000 U/min. (DIN6499 ER)

REGO-FIX Mandrin pour pinces DIN 69871, forme AD

équilibré pour 22000 tr/min. (DIN6499 ER)



Rabatt: 20%
Rabais: 20%



REGO-FIX▲

333950

REGO-FIX Spannzangenfutter DIN 69893, Form A

gewuchtet für 25000 U/min. (DIN6499 ER)

REGO-FIX Mandrin pour pinces DIN 69893, forme A

équilibré pour 25000 t/min. (DIN6499 ER)



Rabatt: 20%
Rabais: 20%

REGO-FIX▲

332400

REGO-FIX Spannzangenfutter BIG PLUS® MAS BT+

Form A/AD, gewuchtet für 22000 U/min. (DIN6499 ER)

REGO-FIX Mandrin pour pinces BIG PLUS® MAS BT+

forme A+AD, équilibré pour 22'000 tr/min. (DIN6499 ER)



Rabatt: 15%
Rabais: 15%

REGO-FIX▲

334100

REGO-FIX Spannzangenfutter CAPTO DIN ISO 26623

feingewuchtet G2.5 / 25'000 min-1. (DIN6499 ER)

REGO-FIX Mandrin pour pinces CAPTO DIN ISO 26623

équilibrage fin G2.5 / 25'000 min-1. (DIN6499 ER)



Rabatt: 15%
Rabais: 15%

REGO-FIX▲

339045

REGO-FIX Spannzange ER-DM (metallisch dichtend)

REGO-FIX Pince ER-DM (étanchéité métallique)



Rabatt: 20%
Rabais: 20%

REGO-FIX▲

339044

REGO-FIX Spannzange ER-CB (CoolBore)

REGO-FIX Pince de serrage ER-CB (CoolBore)



Rabatt: 15%
Rabais: 15%

REGO-FIX 

339060

REGO-FIX Sortiment Spannzangen ER DIN 6499

REGO-FIX Assortiment de pinces ER DIN 6499



Rabatt: 20%
Rabais: 20%

Aufnahmen / Porte-outils

TEKUSA AG 

CLEVER SOLUTIONS

339705

TEKUSA Kegelreiniger ER (Für Spannzangenfutter)

Nettoyeur pour cônes ER (Pour mandrin de pinces)



Rabatt: 15%
Rabais: 15%

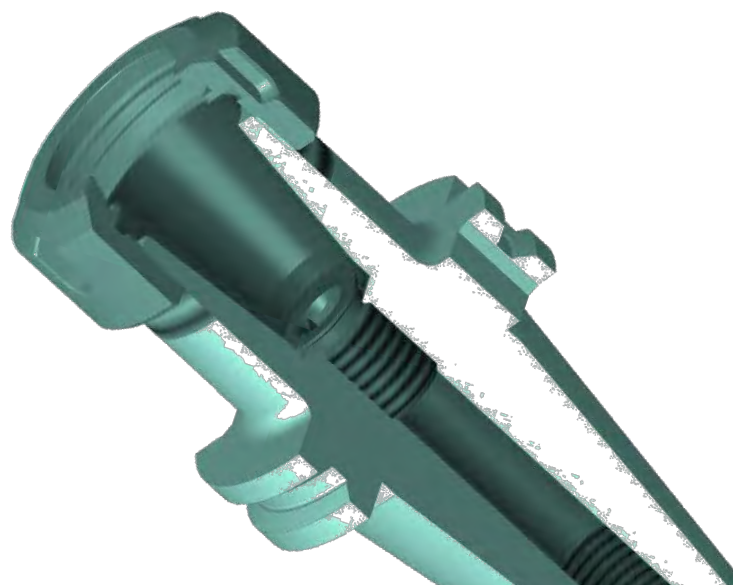

FUTURO

331543

FUTURO NC-Präzisionsbohrfutter DIN 69893

Form A, feingewuchtet G2.5/ 20'000 min-1

FUTURO Foret de précision NC DIN 69893

forme A, équilibrage de précision G2.5 / 20'000 tr/min



Rabatt: 20%
Rabais: 20%

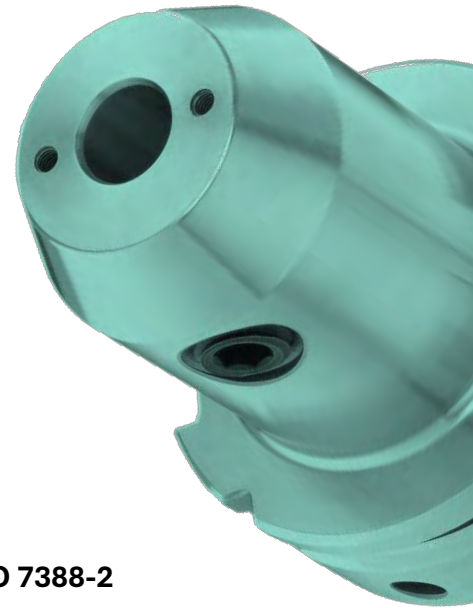

FUTURO

331354

FUTURO NC-Präzisionsbohrfutter ISO 7388-2

Form AD, feingewuchtet G2.5/ 20'000 min-1

FUTURO Foret de précision NC ISO 7388-2

forme AD, équilibrage de précision G2.5 / 20'000 min-1



Rabatt: 20%
Rabais: 20%

NERIOX

330941

NERIOX Flächenspannfutter HSK-A63 mit Kühlkanalbohrung

DIN 69893, Form A, Wuchtgüte G2.5/25'000min-1

NERIOX Mandrin de serrage à méplat HSK-A63, avec arrosage

DIN 69893, forme A, qualité d'équilibrage G2.5/25'000 min-1

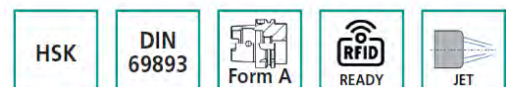

Rabatt: 25%
Rabais: 25%

NERIOX

330943

NERIOX Flächenspannfutter HSK-A63 DIN 69893

Form A, Wuchtgüte G6.3/20'000min-1

NERIOX Mandrin de serrage à méplat HSK-A63 DIN 69893

forme A, qualité d'équilibrage G6.3/20'000min-1



HSK

DIN
69893



Rabatt:
Rabais: 25%



NERIOX

330948

NERIOX Messerkopfaufnahme HSK-A63 mit Kühlkanalbohrung

DIN 69893 A, Wuchtgüte G6.3/20'000 min-1

NERIOX Porte-fraise à plaquettes HSK-A63 avec arrosage

DIN 69893, forme A, qualité d'équilibrage G6.3/20'000 min-1



HSK

DIN
69893



Rabatt:
Rabais: 25%

NERIOX

330947

NERIOX Kombi-Aufsteckfräsdorn HSK-A63, A=100

DIN 69893 A, Wuchtgüte G6.3/20'000min-1

NERIOX Porte-fraise à surfacer HSK-A63, A=100

DIN 69893 A, qualité d'équilibrage G6.3/20'000 min-1



HSK

DIN
69893



Rabatt:
Rabais: 25%

Aufnahmen / Porte-outils

 **SCHAUBLIN**

347820

SCHAUBLIN Spannzange Typ W

SCHAUBLIN Pince type W



Rabatt: **10%**
Rabais: **10%**

 **SCHAUBLIN**

347810

SCHAUBLIN Spannzange Typ F (Rund)

SCHAUBLIN Pince Type F (Ronde)



Rabatt: **10%**
Rabais: **10%**

 **RÖHM**

342500

ROEHM Einsteckkonus (Morsekegelschaft)

ROEHM Queue de montage (Queue cône Morse)



Rabatt: **20%**
Rabais: **20%**

Spannmittel / Outils de serrage

ALBRECHT

341000

ALBRECHT Schnellspann-Bohrfutter (SBF)

ALBRECHT Mandrin à serrage rapide (SBF)



Rabatt: **20%**
Rabais: **20%**



ALBRECHT

341010

ALBRECHT Schnellspann-Bohrfutter einteilig

ALBRECHT Mandrin à serrage rapide en une partie



Rabatt: **20%**
Rabais: **20%**

ALBRECHT

341060

ALBRECHT Schnellspann-Bohrfutter CNC

ALBRECHT Mandrin à serrage rapide CNC



Rabatt: **20%**
Rabais: **20%**

Spannmittel / Outils de serrage



349011

RÖHM Dreibackenfutter

Duro-M, DIN 6350,

zylindrische Zentrieraufnahme

RÖHM Mandrin à 3 mors

Duro-M, DIN 6350,

logement de centrage cylindrique



**Brütsch-Rüegger
Tools**

Rabatt: 15%
Rabais:



349041

RÖHM Dreibackenfutter

Duro-M, ISO 702-2,

Camlock Kurzkegelaufnahme

RÖHM Mandrin à 3 mors

Duro-M, Camlock, ISO 702-2,

Ouverture à glissière courte Camlock



Rabatt: 15%
Rabais:

Spannmittel / Outils de serrage





344000

ROTOR Mitlaufende Zentrierspitze 60° (Main-Line, Typ N)

ROTOR Point de centrage tournant 60° (Main-Line, Typ N)



Rabatt: 15%
Rabais: 15%



344070

ROTOR Mitlaufende Zentrierspitze 60° (Main-Line, Typ L)

ROTOR Point de centrage tournant 60° (Main-Line, Typ L)



Rabatt: 15%
Rabais: 15%



344210

ROTOR Mitlaufende Zentrierspitze 60° (Speed-Line, Typ E-B)

ROTOR Point de centrage tournant 60° (Speed-Line, Typ E-B)



Rabatt: 15%
Rabais: 15%

Zentrierspitzen / Points de centrage

 **POINTTECH**

344500

POINTTECH Mitlaufende Zentrierspitze 60° (Typ WP, hochpräzise Ausführung)

POINTTECH Pointe de tour tournante 60° (Type WP, version haute précision)



Rabatt:
Rabais: **10%**

Zentrierspitzen / Points de centrage

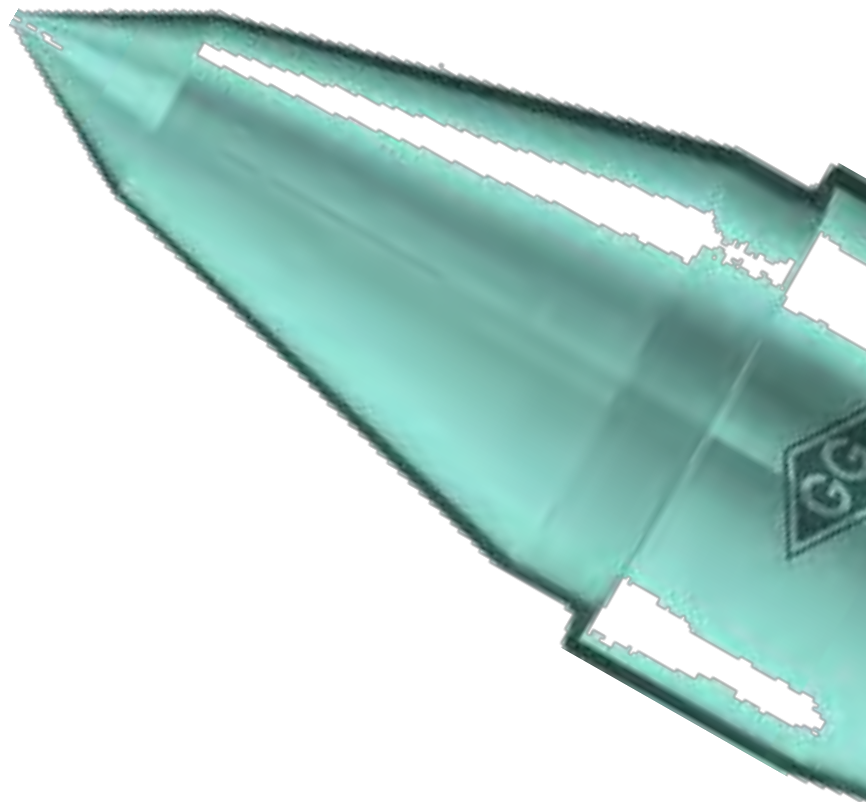

 **POINTTECH**

344505

POINTTECH Mitlaufende Zentrierspitze 30°/60° (Type WPL30)

POINTTECH Pointe de tour tournante 30°/60° (Type WPL30)



Rabatt:
Rabais: **10%**



362000

AMF Senkrechtspanner (Nr. 6800)

(Offener Haltearm und waagrechter Fuss)

AMF Sauterelle poussée (Nr. 6800)

(Bras d'arrêt ouvert et pied à l'horizontale)

Rabatt: 30%
Rabais: 30%

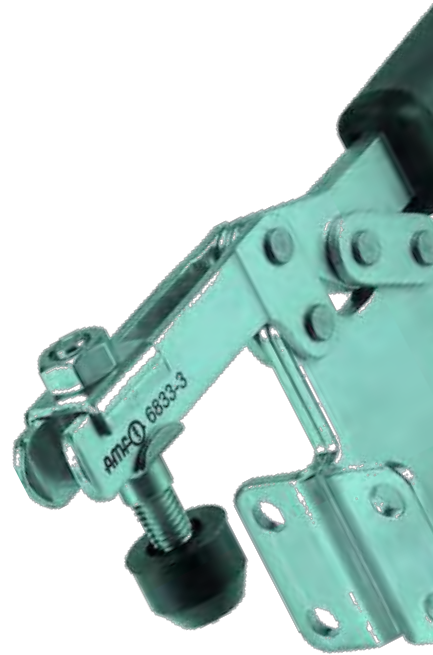

Schnellspanner / Sauterelles



362100

AMF Waagrechtspanner (Nr. 6830)

(Offener Haltearm und waagrechter Fuss)

AMF Sauterelle tirée (Nr. 6830)

(Bras de maintien ouvert et pied horizontal)

Rabatt: 30%
Rabais: 30%



362520

AMF Waagrechtspanner (Nr. 6830 NI)

(Offener Haltearm und waagrechter Fuss)

AMF Sauterelle tirée (Nr. 6830 NI)

(Bras de maintien ouvert et pied horizontal)

Rabatt: 25%
Rabais: 25%





362500

AMF Senkrechtspanner (Nr. 6800 NI)

(Offener Haltearm und waagrecht Fuss)

AMF Sauterelle poussée (Nr. 6800 NI)

(Bras d'arrêt ouvert et pied à l'horizontale)

Rabatt: 25%
Rabais: 25%



362240

AMF Schubstangenspanner

(Mit kleinem Winkelfuss) (Nr. 6841)

AMF Sauterelle à tige coulissante

(Avec petit pied angulaire) (Nr. 6841)

Rabatt: 30%
Rabais: 30%



Schnellspanner / Sauterelles

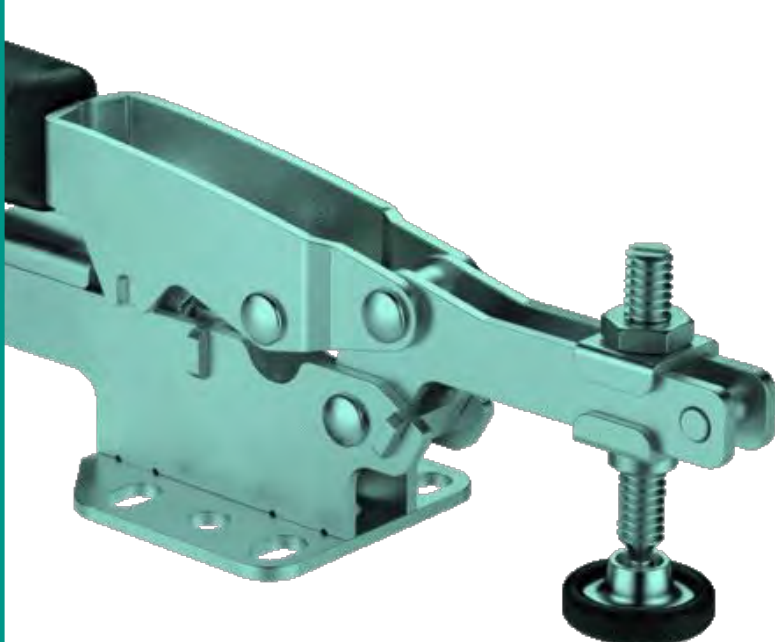



357120

AMF Spannpratze "Krokodil" (Nr. 6312V)
(Spannpratze mit Gegenhalter)

AMF Griffes de serrage «crocodile» (Nr. 6312V)
(Griffes de serrage avec contre-pièce)

Rabatt: **30%**
Rabais: **30%**



357480

AMF Atlas-Schraubbock (Nr. 6430S)
(mit Gegenmutter, Trapezgewinde)

AMF Vérin à vis Atlas (Nr. 6430S)
(avec contre-écrou, filetage trapézoïdal)

Rabatt: **30%**
Rabais: **30%**



357200

AMF Spanneisen abgeschrägt (Nr. 6314V)
(mit verstellbarer Stützschaube)

AMF Bride biseautée (Nr. 6314V)
(avec vis d'appui réglable, entièrement)

Rabatt: **30%**
Rabais: **30%**





357380

AMF Schraubbock, Ø 12 mm (Nr. 6400)
(mit flacher Auflage und Zentrierbohrung)

AMF Vérin à tête plate, Ø 12 mm (Nr. 6400)
(avec surface plate et trou de centrage)

Rabatt: **30%**
Rabais: **30%**



357040

AMF Gabelspanneisen abgeschrägt (DIN 6315B)
(Vergütungsstahl lackiert)

AMF Bride à fourche simple (DIN 6315B)
(acier traité, verni)

Rabatt: **30%**
Rabais: **30%**

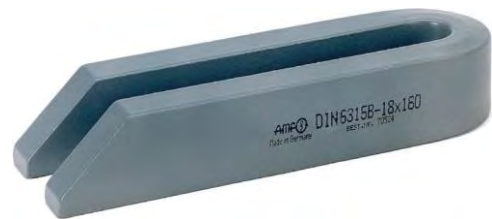

357060

AMF Gabelspanneisen mit Nase (Nr. 6315GN)
(Vergütungsstahl lackiert)

AMF Bride avec nez (Nr. 6315GN)
(acier traité, verni)

Rabatt: **30%**
Rabais: **30%**

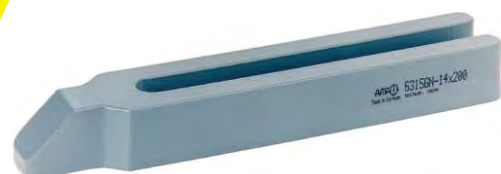



357800

AMF Kraftspanner

(Stufenlos verstellbares Spannelement)

AMF Bride surpuissante

(Élément de bridage réglable en continu)

Rabatt:
Rabais: **25%**



357801

AMF Zwischenelement

(Komplett mit Befestigungssatz)

AMF Élément intermédiaire

(Complet avec jeu de fixation)

Rabatt:
Rabais: **25%**



357802

AMF Druckstück Edelstahl, rostfrei

(Komplett mit Spannstift)

AMF Patin d'appui Acier inoxydable

(Complet avec goupille élastique)

Rabatt:
Rabais: **25%**



KOPAL®

354000

KOPAL Spannelement Piccolo
*(Kompaktes Spannsystem für
vertikales, kräftiges Spannen
bei kleinem Platzbedarf)*

KOPAL Elément de serrage Piccolo
*(Système de serrage compact
pour un serrage puissant,
vertical, dans des
espaces réduits)*

Rabatt: **30%**
Rabais: **30%**



KOPAL®

354100

KOPAL Spannelement Monobloc
*(Spannsystem für vertikales, kräftiges
Spannen, Ohne Spannschlüssel,
ohne Befestigungsschraube)*

KOPAL Elément de serrage Monobloc
*(Système de serrage pour un
serrage puissant, vertical
sans clé de serrage,
sans vis de fixation)*

Rabatt: **30%**
Rabais: **30%**





360440

AMF Sortimentskasten

Spannwerkzeuge

AMF Coffret d'assortiment

d'éléments de serrage

Rabatt: 30%
Rabais: 30%



360420

AMF Sortimentskasten

Spannschrauben für T-Nuten

AMF Coffret d'assortiment

de boulons de serrage à tête à T

Rabatt: 30%
Rabais: 30%



360460

AMF Sortimentskasten

Spannwerkzeuge

AMF Coffret d'assortiment

d'éléments de serrage

Rabatt: 30%
Rabais: 30%



360500

AMF Spannelemente-Satz

aus Kunststoff

AMF Jeu d'éléments

de serrage en plastique

Rabatt: 25%
Rabais: 25%



ALLMATIC
Spannsysteme JAKOB

410911

ALLMATIC NC- Hochdruckspanner Typ HD

ALLMATIC Étau haute pression NC Type HD



ab:
dès: **2596.-** CHF

statt / au lieu de : CHF ~~3246.-~~

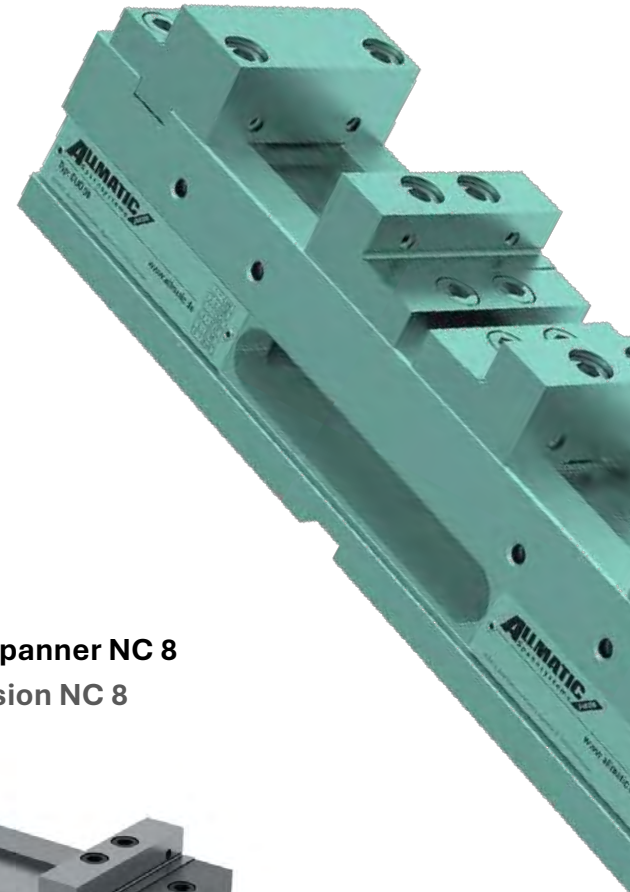

ALLMATIC
Spannsysteme JAKOB

411020

ALLMATIC NC-Hochdruckspanner NC 8

ALLMATIC Étau haute pression NC 8



ab:
dès: **2269.-** CHF

statt / au lieu de : CHF ~~2837.-~~

ALLMATIC
Spannsysteme JAKOB

411022

ALLMATIC NC-Hochdruckspanner NC 4

ALLMATIC Étau haute pression NC 4



ab:
dès: **1990.-** CHF

statt / au lieu de : CHF ~~2488.-~~

Schraubstöcke / Étaux



TSCHORN[®]
Mess- und Spannmittel

337346

TSCHORN 3D-Kantentaster (3D Digital)

TSCHORN Palpeur d'arêtes 3D (3D NUMÉRIQUE)

318.— CHF

statt / au lieu de : CHF ~~378.-~~



REGO-FIX 

337316

REGO-FIX 3D-Kantentaster

Verkürzte Rüstzeit und höhere Präzision mit 3D-EdgeMaster

REGO-FIX Palpeur d'arêtes 3D

Temps de préparation réduit et précision élevée avec 3D-EdgeMaster

258.— CHF

statt / au lieu de : CHF ~~356.-~~





417351

AMF Marker Medium / Small / Slimline

Nr. 1570MM / 1580MS / 1590MSL

AMF Marker Extra Medium / Small / Slimline

N° 1570MM / 1580MS / 1590MSL

Rabatt: 20%
Rabais: 20%



417350

AMF Marker Extra Large / Large

Nr. 1550MXL / 1560ML

AMF Marker Extra Large / Large

N° 1550MXL / 1560ML

Rabatt: 20%
Rabais: 20%



417352

AMF Markiernadeln

zu AMF Marker

AMF Aiguilles de marquage

pour AMF Marker

Rabatt: 20%
Rabais: 20%



FUTURO

417370

FUTURO Reinigungspropeller Chip-Blower

FUTURO Hélice de nettoyage Souffleur de copeaux



158.— CHF

statt / au lieu de : CHF ~~178.-~~



AMF

417360

AMF Cleaner Ausführung Ball

Nr. 1510CBVC

AMF Cleaner exécution Ball

N° 1510CBVC

298.— CHF

statt / au lieu de : CHF ~~360.-~~



AMF

417360

AMF Cleaner Ausführung Ball

Nr. 1510CBH

AMF Cleaner exécution Ball

N° 1510CBH

298.— CHF

statt / au lieu de : CHF ~~360.-~~



PWB+

334220

Werkzeug-Montageblock TOOL BOY

Appareil de montage TOOL BOY

Der vielseitige und sichere Montagehalter für Werkzeuge mit unterschiedlichsten Aufnahmen.

L'appareil de montage pour le logement d'outils et de systèmes d'outils modulaires.



ab:
dès: **484.-** CHF
statt / au lieu de : CHF ~~570.-~~

TOOL-BOY

FUTURO

230133

**FUTURO Sortiment HM-Frässtifte
(Kopfdurchmesser 10mm)**

FUTURO Assortiment de fraise rotative
carbure (Diamètre de tête 10mm)

P	M	K	N	S	H	O
	●●			○		

Rabatt: 30%
Rabais: 30%

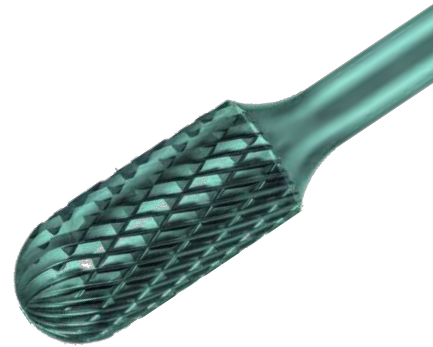

FUTURO

230132

**FUTURO Sortiment HM-Frässtifte
(Kopfdurchmesser 10mm)**

FUTURO Assortiment de fraise rotative
carbure (Diamètre de tête 10mm)

P	M	K	N	S	H	O
●●		○				

Rabatt: 30%
Rabais: 30%



FUTURO

230135

**FUTURO Sortiment HM-Frässtifte
(Kopfdurchmesser 1mm und 1.5mm)**

FUTURO Assortiment de fraise rotative
carbure (Diamètre de tête 1mm und 1.5mm)

P	M	K	N	S	H	O
○	○	○	○	○	○	

Rabatt: 35%
Rabais: 35%



FUTURO

335415

FUTURO Mikro - Ausdrehkopf
(Ø 0.3 - 19.1 digital)

FUTURO Micro-tête d'alésage
(Ø 0.3 - 19.1 digitale)

Rabatt: 20%
Rabais: 20%



FUTURO

335400

FUTURO Feinausdrehset
(Ø9.75 - 30.1)

FUTURO Kit d'alésage fin
(Ø9.75 - 30.1)

Rabatt: 15%
Rabais: 15%

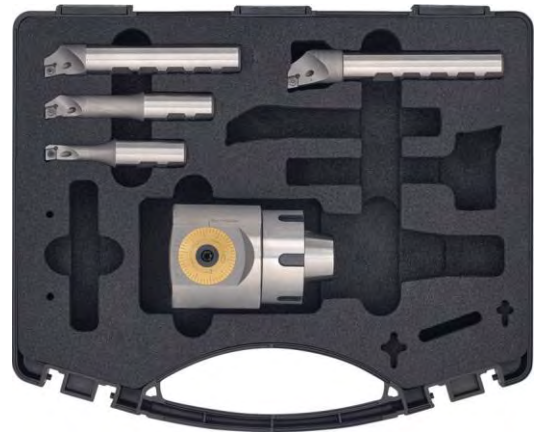

Ausdrehköpfe / Tête d'alésage

FUTURO

335405

FUTURO Feinausdrehset
(Ø9.75 - 101.1)

FUTURO Kit d'alésage fin
(Ø9.75 - 101.1)

Rabatt: 15%
Rabais: 15%

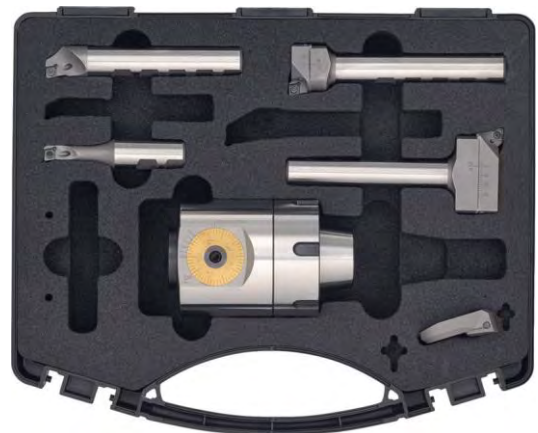

NERIOX

272191

NERIOX Gewindeschneid-Set M3 - M12

**In stabilem Kunststoffkoffer mit Tragegriff,
übersichtlich eingeteilt.**

NERIOX Jeu d'outils de filetage M3 - M12

**Dans un coffret en plastique solide
avec poignée de transport, bien agencé.**



298.- CHF

statt / au lieu de : CHF ~~375.-~~



M3 - M12



**Brütsch-Rüegger
Tools**

Brütsch/Rüegger Werkzeuge AG

Heinrich Stutz-Strasse 20

Postfach · 8902 Urdorf · Schweiz

Tel. +41 44 736 63 63 · Fax +41 44 736 63 00

www.brw.ch · info@brw.ch

Preisgültigkeit: bis 31.12.2024, Preise netto, exkl. MwSt., exkl. VRG/VEG und exkl. VOC, unverpackt ab Zürich/Urdorf. Unser Angebot richtet sich an Firmenkunden zur Nutzung beruflicher oder gewerblicher Zwecke. Die Bestellung erfolgt auf Grundlage unserer AGBs. (www.brw.ch)
Validité de prix jusqu'au 31.12.2024, prix net, hors TVA, hors TAR/TEA et hors taxe OCOV, sans emballage au départ Zurich/Urdorf. Notre offre s'adresse aux clients d'entreprises pour utilisation à des fins professionnelles ou industrielles. La commande est effectuée sur base de nos CGV. (www.brw.ch)